

# LCN-IW65

## Complete Wind Sensor in the IP65 Case

### Functional Specifications:

The LCN wind sensor counts the pulses of the wind turbine. The turbine delivers 8 pulses per revolution. The pulses are recorded with the LCN-IV on the I-Port connection of the LCN bus module and internally evaluated and actions carried out depending on the parameters set.  
The LCN-IW65 needs a 230V power supply as well as the LCN data line for bus communication.

### Hardware equipment:

- 1 x LCN-UPP
- 1 x LCN-IV
- 1 x LCN-IW



### Description:

The LCN-IW65 is a wind sensor (wind turbine) and comes complete with an impulse counter cable and an integrated LCN bus modul for the evaluation of the data captured. The parameters of the LCN bus module are set using the system software LCN-P or LCN-PRO.

The case is weather-proof (IP 65) and has a connection cable with a length of approximately 3 metres. It comes complete with the necessary assembly kit for wall and pylon fixture.

### Field of application:

The LCN-IW65 is used for the recognition of wind forces. So awnings, shutters and other facilities that are sensitive to wind can be protected.

The parameters for the above functions are set in the bus module using the LCN-P or PRO software.

# LCN-IW65

## Complete Wind Sensor in the IP65 Case

### Measurements:

**Wind Sensor (L x W x H):** 40 mm x 40 mm x 95 mm,  
**Rotor (Ø):** 105 mm

**Exterior Case:** 120 mm x 80 mm x 50 mm

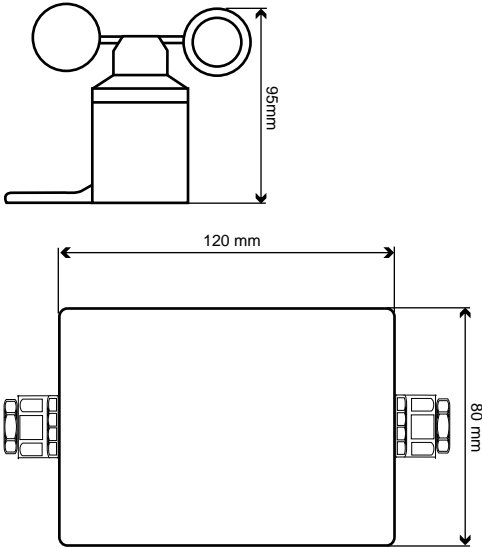

**Assembly:** screw fixture

### Technical Data:

**Connection:**  
**Power supply:** 230V~ ±15%, 50Hz  
**Power capacity:** <0,5W internal consumption  
**Connection power side:** litz wires 0,75 mm<sup>2</sup>(with insulated pin terminals)

**Sensor:**  
**Record range:** 6 - 21m /s  
**Resolution:** 8 pulse per revolution  
**Connection length:** max.100m

**Ports:**  
**T-Port:** available  
**I-Port:** available/ already in use  
**P-Port:** not available

**General Details:**  
**Operating temperature:** -10°C to +40°C  
**Humidity:** max. 80% rel., no condensation

**Environmental conditions:** stationary installation according to VDE 632, VDE 637

**Safety classification:** IP 65

### Circuit Diagram

